

MODEL #304 GROUP FIRE PIT (4' DIA.)

OUTDOOR CREATIONS, INC.

SCALE: 1" = 32"

CUSTOMER APPROVAL x \_\_\_\_\_

DRAWN BY: MNC

ELEVATION

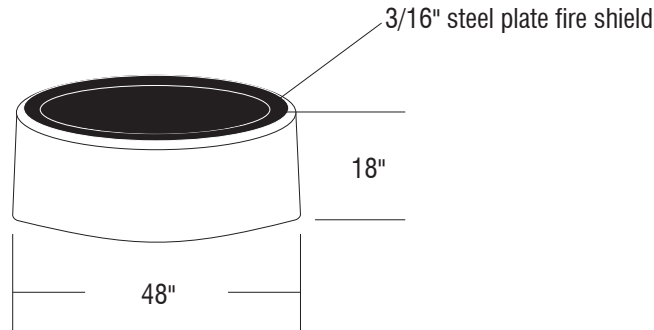

SECTION

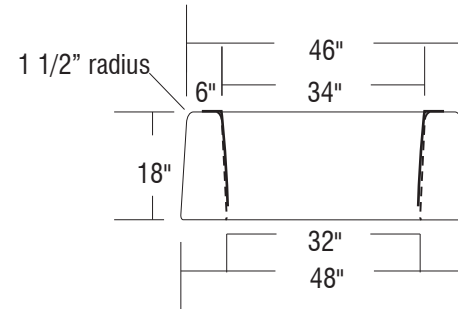

PLAN

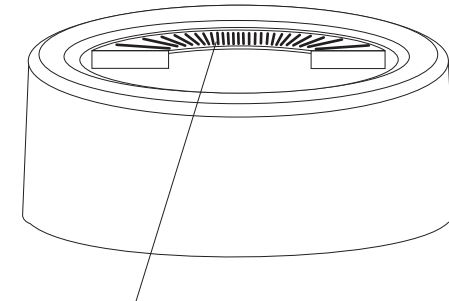
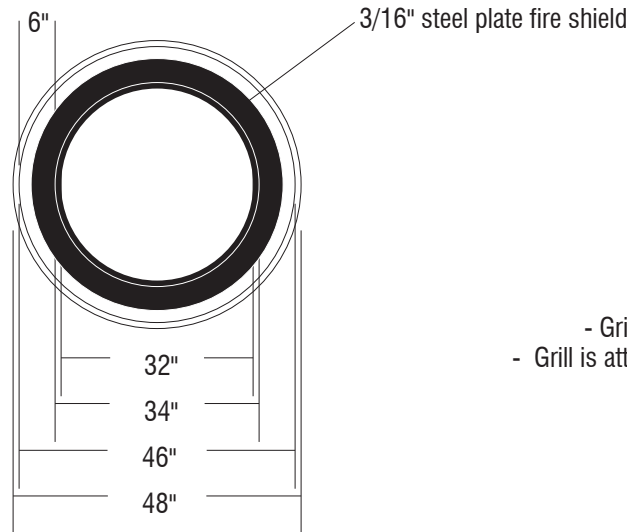

- \* Optional 1/2 grill (Model # 304G)
- Grill is laser cut from single sheet 3/8" steel
- Grill is attached to casting with (3) 1/2" x 1" grade 5 bolts

**NOTES:**

1. Concrete mix design to include a mixture of Portland Cement, water, coarse and fine aggregates, pure mineral oxide coloring agents (when applicable) to yield a minimum compressive strength of 5000 psi.
2. Final product shall be reinforced with #4 and #5 rebar grid.
3. Product is cast in 1-piece with no assembly required.
4. Hairline cracks may develop over time. These are not structural failures, but inherent characteristics of the material itself.
5. Air pockets are a common occurrence in precast products. The frequency and size of air pockets are variable and to be expected, especially on vertical surfaces.
6. Concrete corners and edges will chip if not handled according to guidelines. Patch kits are available but may or may not blend and can be variable.
7. There is a level of care and maintenance associated with your product and is the responsibility of the end user. Choosing the right sealer can help minimize those costs.

*\*Fire rings are designed to accommodate small campfires only. Large fires, including those that reach a height of 12" or more and/or envelop the entire ring, create excessive heat conditions that may damage the ring. Outdoor Creations Inc is not responsible for damage occurring from conditions beyond normal size camp fires.*

**WEIGHT: 1350 LBS**  
**TEXTURE:**  
**COLOR:**  
**SEALER:**

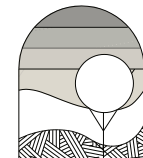

**OUTDOOR CREATIONS INC.**  
 2270 Barney Street  
 Anderson, CA 96007  
 (530) 365-6106  
 FAX (530) 365-5129