

MODEL #511 - (2) COMPARTMENT CONCRETE TRASH/RECYCLING RECEPTACLE

OUTDOOR CREATIONS, INC.

SCALE: 1" = 24"

CUSTOMER APPROVAL x _____

DRAWN BY: MNC

SIDE ELEVATION

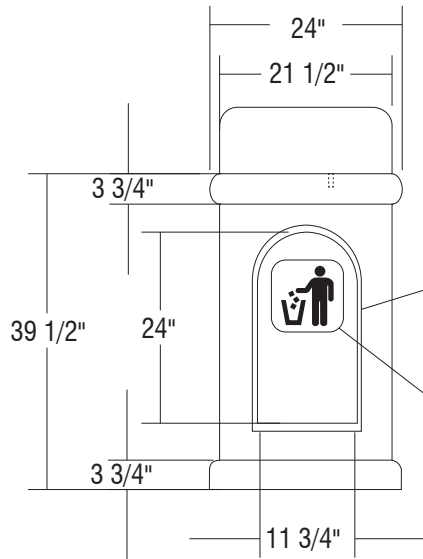

Steel Door Powder Coated Std. Color "Bronze" on trash side of unit. "Trash" decal applied to door - White

3/4" chamfer around 3/4" deep inlay area

"Trash" logo cast in full relief and painted "Black" on "White" Background of trash side of receptacle

FRONT ELEVATION

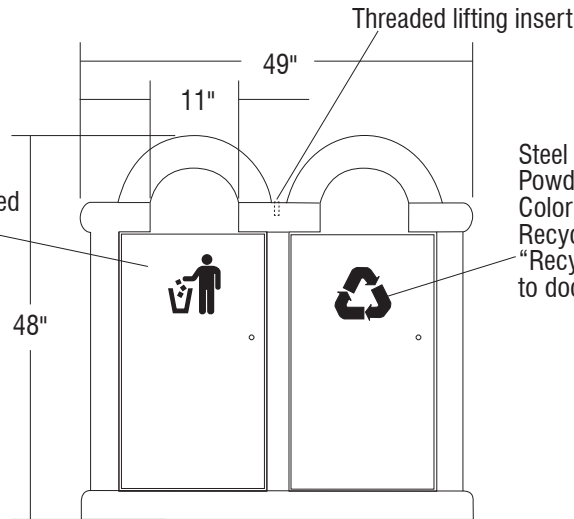

Steel Door Powder Coated Color "Recycle Blue" on Recycle side of unit. "Recycle" decal applied to door - White

SIDE VIEW



"Recycle" logo cast in full relief and painted "Recycle Blue" on "White" Background of recycle side of receptacle

PLAN VIEW

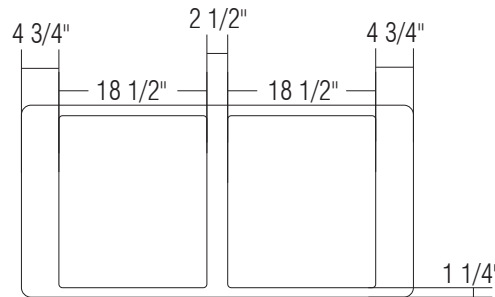

*Unit includes (2) Plastic Liners: SQT29

REAR ELEVATION

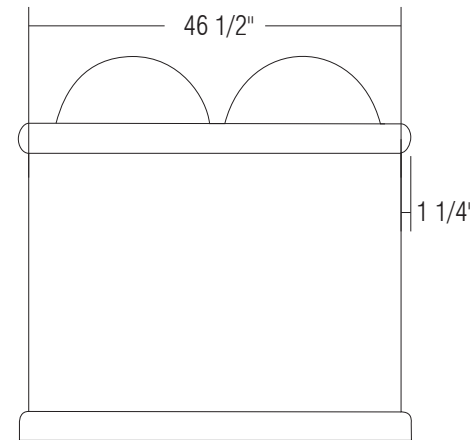

NOTES:

1. Concrete mix design to include a mixture of Portland Cement, water, coarse and fine aggregates, pure mineral oxide coloring agents (when applicable) to yield a minimum compressive strength of 5000 psi.
2. Final product shall be reinforced with #4 and #5 rebar grid.
3. Product is cast in 1-piece with no assembly required.
4. Hairline cracks may develop over time. These are not structural failures, but inherent characteristics of the material itself.
5. Air pockets are a common occurrence in precast products. The frequency and size of air pockets are variable and to be expected, especially on vertical surfaces.
6. Concrete corners and edges will chip if not handled according to guidelines. Patch kits are available but may or may not blend and can be variable.
7. There is a level of care and maintenance associated with your product and is the responsibility of the end user. Choosing the right sealer can help minimize those costs.

WEIGHT: 1800 LBS
TEXTURE:
COLOR:
SEALER:

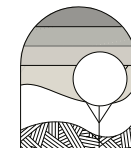

OUTDOOR CREATIONS INC.
 2270 Barney Street
 Anderson, CA 96007
 (530) 365-6106
 FAX (530) 365-5129